

## BIOCHEMISTRY

# Biochemical pedomorphosis and genetic assimilation in the hypoxia adaptation of Tibetan antelope

Anthony V. Signore and Jay F. Storz\*

Developmental shifts in stage-specific gene expression can provide a ready mechanism of phenotypic change by altering the rate or timing of ontogenetic events. We found that the high-altitude Tibetan antelope (*Panthelops hodgsonii*) has evolved an adaptive increase in blood-O<sub>2</sub> affinity by truncating the ancestral ontogeny of globin gene expression such that a high-affinity juvenile hemoglobin isoform (isoHb) completely supplants the lower-affinity isoHb that is expressed in the adult red blood cells of other bovids. This juvenilization of blood properties represents a canalization of an acclimatization response to hypoxia that has been well documented in adult goats and sheep. We also found the genomic mechanism underlying this regulatory isoHb switch, revealing how a reversible acclimatization response became genetically assimilated as an irreversible adaptation to chronic hypoxia.

## INTRODUCTION

When members of multigene families are developmentally regulated, shifts in the stage-specific expression of individual genes can provide a ready mechanism of phenotypic change by altering the rate or timing of ontogenetic events (heterochrony). For example, retained activity of early-expressed genes in later stages of ontogeny can result in the retention of juvenile characters into adulthood, a well-documented developmental mechanism of phenotypic evolution (1, 2). In extreme cases, deceleration of development can produce a truncation of the ancestral ontogeny, resulting in the juvenilization of the adult-expressed phenotype, a phenomenon known as pedomorphosis.

In jawed vertebrates, the subfamilies of genes that encode the  $\alpha$ - and  $\beta$ -type subunits of tetrameric hemoglobin (Hb) are developmentally regulated such that structurally and functionally distinct  $\alpha_2\beta_2$  Hb isoforms (isoHbs) are expressed during different ontogenetic stages. During mammalian development, different pre- and postnatally expressed isoHbs have evolved different oxygenation properties and perform distinct O<sub>2</sub>-scavenging/O<sub>2</sub>-transport tasks during different ontogenetic stages (3–6). Genetically based shifts in stage-specific isoHb expression could therefore provide a heterochronic mechanism of evolutionary change in respiratory gas transport and aerobic metabolism. Similarly, in humans, hereditary persistence of fetal Hb alleviates the severity of thalassemias and other pathologies affecting the synthesis or stability of adult Hb (7).

Prenatally expressed isoHbs of eutherian mammals typically exhibit substantially higher O<sub>2</sub> affinities than adult-expressed isoHbs (3, 5, 6). In anthropoid primates and bovid artiodactyls, expression of a high-affinity fetal isoHb during late stages of prenatal development helps to maintain an O<sub>2</sub> affinity difference between fetal and maternal circulations, thereby facilitating O<sub>2</sub> transfer across the placental barrier (5, 6). Given that increased Hb-O<sub>2</sub> affinity is generally beneficial under conditions of severe hypoxia due to the importance of safeguarding arterial O<sub>2</sub> saturation (6, 8–11), the retention of early isoHb expression into adulthood could provide an effective mechanism of adaptation to chronic O<sub>2</sub> deprivation. Consistent with this hypothesis, when adult goats and sheep are exposed to acute hypoxia, they up-regulate a juvenile isoHb at the expense of the normal adult isoHb (12, 13). Here, we report the discovery of a

canalized version of this response in the high-altitude Tibetan antelope, *Panthelops hodgsonii* (Artiodactyla: Bovidae), a champion among mammals in aerobic exercise performance under hypoxia. This species is endemic to the Tibetan Plateau and lives at altitudes of 3600 to 5500 m above sea level. At an altitude of 5500 m, the partial pressure of O<sub>2</sub> (P<sub>O<sub>2</sub></sub>) is roughly half the value at sea level, a level of hypoxia that severely compromises aerobic exercise performance in humans and most other mammals (14–16). However, at these altitudes, Tibetan antelope can sustain running speeds of >70 km/hour over distances of >100 km (17).

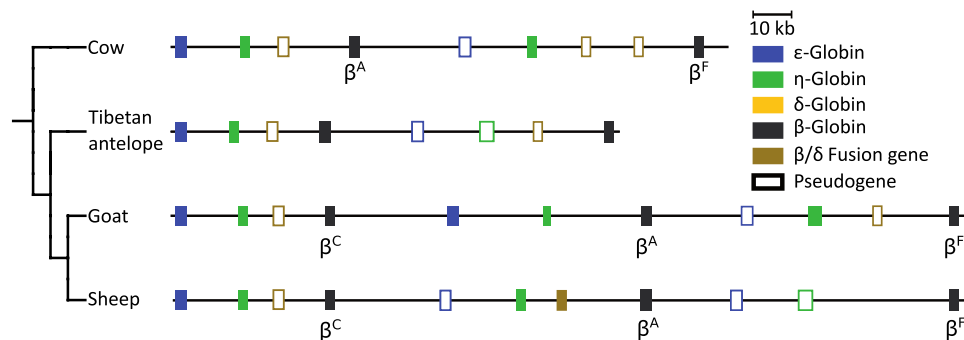
In addition to documenting the phenotypic consequences of developmentally displacing the low-affinity adult isoHb with a higher-affinity juvenile isoHb—a form of biochemical pedomorphosis—we also found the genomic mechanism by which the up-regulation of the juvenile isoHb became canalized in Tibetan antelope. Specifically, we document how a reversible acclimatization response to acute hypoxia—as observed in modern-day sheep and goats—became genetically assimilated as an irreversible adaptation to chronic hypoxia.

## RESULTS AND DISCUSSION

We characterized the genomic organization of globin genes in Tibetan antelope and other bovid artiodactyls using published genome assemblies (18). Among mammals, bovid artiodactyls are unusual in that the entire  $\beta$ -globin gene cluster has undergone multiple rounds of en bloc duplication involving the same set of pre- and postnatally expressed  $\beta$ -type globin genes (Fig. 1) (19–21). Cows (*Bos taurus*) have two duplicated gene blocks, each containing separate paralogs of the  $\beta$ -globin gene,  $\beta^A$  and  $\beta^F$ , in the 5' and 3' blocks, respectively (Fig. 1). As with other eutherian mammals, the product of  $\beta^A$  is incorporated into an adult-expressed isoHb, HbA ( $\alpha_2\beta^A_2$ ), whereas the  $\beta^F$  gene has been recruited for prenatal expression and is incorporated into a fetal isoHb, HbF ( $\alpha_2\beta^F_2$ ) (22). Goats (*Capra hircus*) and sheep (*Ovis aries*) have an additional gene block at the 5' end of the cluster that contains a third  $\beta$ -globin paralog,  $\beta^C$  (Fig. 1) (19–21). Whereas the  $\beta^A$  and  $\beta^F$  genes in goats and sheep have retained the same developmental expression profiles as their respective orthologs in cow, the  $\beta^C$  gene has been recruited for a new ontogenetic stage of expression during the first few months of neonatal life, and its product is incorporated into a juvenile isoHb, HbC ( $\alpha_2\beta^C_2$ ) (23).

University of Nebraska, School of Biological Sciences, Lincoln, NE 68588, USA.

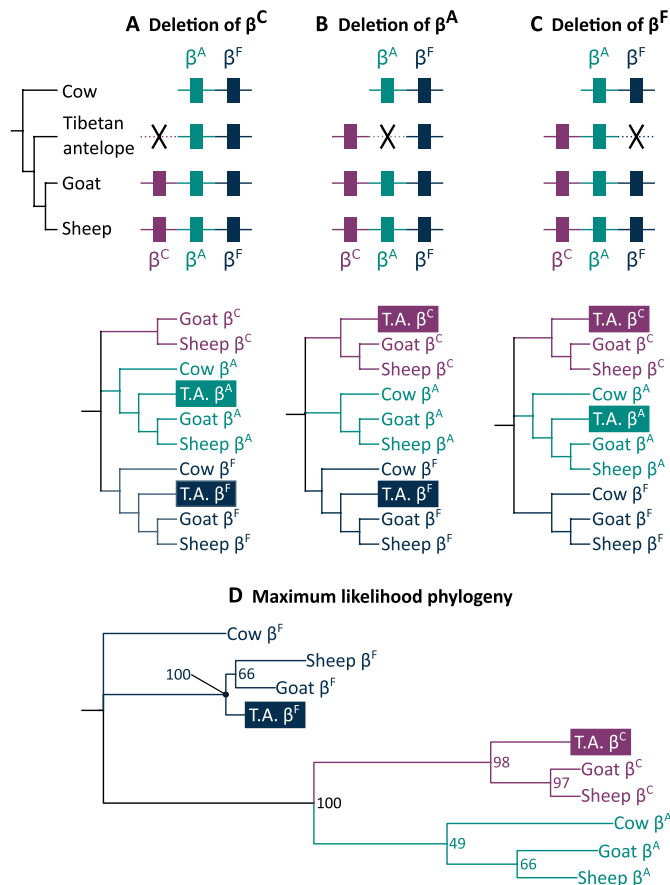
\*Corresponding author. Email: jstorz2@unl.edu



**Fig. 1. Genomic organization of bovid  $\beta$ -globin gene clusters.** Colored boxes represent individual genes. Labels denote previously annotated  $\beta^C$ -,  $\beta^A$ -, and  $\beta^F$ -globin genes.

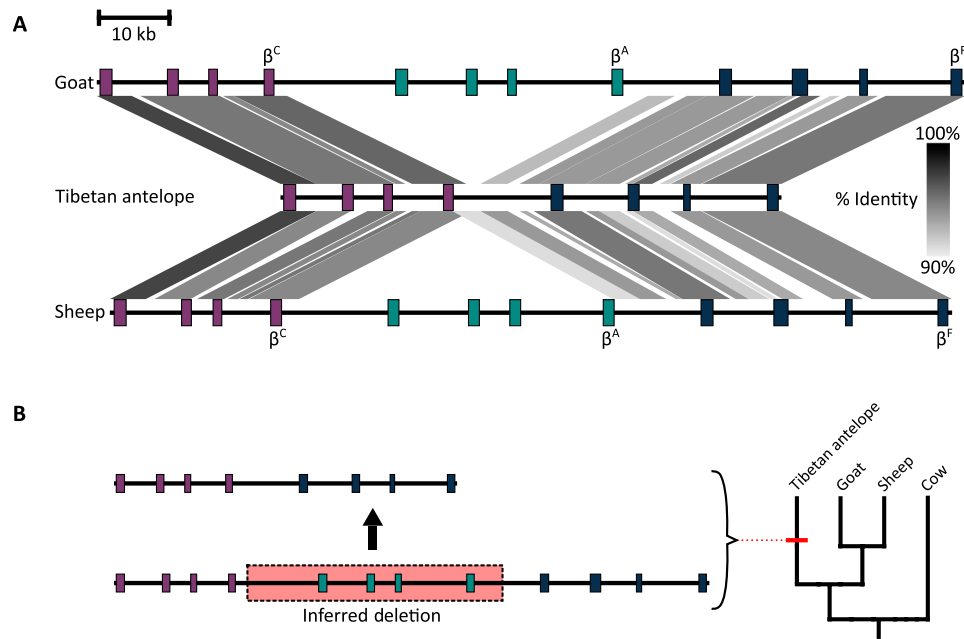
The  $\beta$ -globin gene cluster of Tibetan antelope appears superficially similar to that of cow in terms of gene content (Fig. 1), suggesting that the Tibetan antelope inherited the same pair of  $\beta^A$ - and  $\beta^F$ -containing gene blocks. The alternative hypothesis is that Tibetan antelope inherited the additional en bloc duplication observed in goats and sheep but one of the triplicated gene blocks was secondarily deleted, in which case the sole remaining pair of  $\beta$ -globin genes would be represented by one of three possible combinations:  $\beta^A + \beta^F$  (a reversion to the ancestral gene complement observed in cow),  $\beta^C + \beta^A$ , or  $\beta^C + \beta^F$  (Fig. 2, A to C). Either of the latter two combinations would implicate a novel isoHb profile that is not observed in other bovid taxa. To distinguish among these three alternative scenarios, we estimated the phylogeny of bovid  $\beta^C$ ,  $\beta^A$ , and  $\beta^F$  genes and the pair of Tibetan antelope  $\beta$ -globin paralogs. Estimated phylogenies (Fig. 2D and fig. S1) demonstrate that the 5' and 3'  $\beta$ -globin genes of Tibetan antelope are orthologous to bovid  $\beta^C$  and  $\beta^F$ , respectively, consistent with the scenario illustrated in Fig. 2B. This result indicates that Tibetan antelope inherited the triplicated set of  $\beta^C$ -,  $\beta^A$ -, and  $\beta^F$ -containing gene blocks observed in goats and sheep (Fig. 1) and that the middle gene block containing  $\beta^A$  was secondarily deleted. This phylogenetic inference is unambiguously corroborated by patterns of conserved synteny and pairwise sequence matches (Fig. 3), as the  $\beta^C$ - and  $\beta^F$ -containing gene blocks of goat and sheep match the 5' and 3' gene blocks in Tibetan antelope. This comparative genomic analysis revealed that a ~45-kb region of the Tibetan antelope  $\beta$ -globin gene cluster was deleted—a gene region that contained the ortholog of the  $\beta^A$  gene that encodes the  $\beta$  chain of adult Hb in bovids and all other mammals.

Deletion of the adult  $\beta^A$  gene in the ancestor of Tibetan antelope effectively truncated the ancestral ontogeny of globin gene expression, such that juvenile HbC completely supplanted HbA in adult red blood cells. Thus, blood- $O_2$  transport in Tibetan antelope has been juvenilized relative to the ancestral phenotype of adult bovids. To examine the effects of this pedomorphic change, we measured the oxygenation properties of purified recombinant Hb from Tibetan antelope and purified native Hbs from adult specimens of 10 other bovid species (Fig. 4 and Table 1). The adult red cells of these other taxa contain HbA alone or in combination with HbC as a minor component (fig. S2). We measured the Hb- $O_2$  affinity of purified total Hb from each bovid species in both the absence (stripped) and presence of 100 mM  $Cl^-$  (in the form of KCl). The stripped treatment provides a measure of intrinsic Hb- $O_2$  affinity, whereas the +KCl treatment provides a measure that is relevant to in vivo conditions in bovid red cells, as  $Cl^-$  ions are the principal allosteric regulators of Hb- $O_2$  affinity (i.e., heme reactivity is modulated oxygenation-

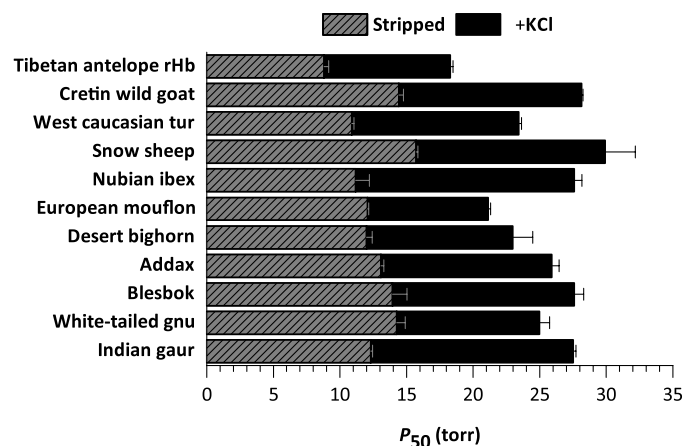


**Fig. 2. Phylogenetic analyses of bovid  $\beta^C$ -,  $\beta^A$ -, and  $\beta^F$ -globin genes.** Alternative histories of gene deletion in Tibetan antelope yield testable phylogenetic hypotheses: (A) Deletion of  $\beta^C$ , (B) deletion of  $\beta^A$ , and (C) deletion of  $\beta^F$ . (D) Estimated maximum likelihood phylogeny of bovid  $\beta$ -type globin genes indicates that Tibetan antelope has retained copies of  $\beta^C$  and  $\beta^F$  and that  $\beta^A$  has been secondarily lost. Bootstrap support values are shown for relevant nodes.

linked binding of  $Cl^-$  ions at sites remote from the heme iron) (6, 22, 24). Results of our in vitro experiments revealed that Hb of Tibetan antelope has a substantially higher  $O_2$  affinity than that of all other bovid taxa (Fig. 4 and Table 1). Hbs of all taxa were similarly responsive to  $Cl^-$ , as the average  $P_{50}$  (the  $PO_2$  yielding 50% Hb- $O_2$  saturation) was 27.1% higher (i.e., Hb- $O_2$  affinity was lower) in the +KCl treatment (Table 1).



**Fig. 3. Analysis of pairwise sequence matches in chromosomal regions containing bovid  $\beta$ -globin gene clusters reveals a large-scale deletion in Tibetan antelope.** Purple, green, and blue colored boxes represent genes within the  $\beta^C$ ,  $\beta^A$ , and  $\beta^F$ -gene blocks, respectively. (A) Gray shading denotes percent sequence identity between homologous  $\beta$ -globin gene clusters. (B) A ~45-kb chromosomal deletion in the  $\beta$ -globin cluster of the Tibetan antelope lineage resulted in secondary loss of the  $\beta^A$ -containing gene block.



**Fig. 4. O<sub>2</sub> affinities of total purified Hb from select bovid species.** O<sub>2</sub> tensions at half saturation ( $P_{50}$ ) for total Hb in the absence (stripped; gray hatched bars) and presence of 0.1 M KCl (black bars) at 37°C (pH 7.4) (0.1 mM Hb<sub>4</sub>). Values are shown as mean  $P_{50} \pm$  SEM ( $n = 3$ ).

As a follow-up experiment, we isolated and purified HbC and HbA from two of the bovid species expressing both components, and we measured isoHb-specific O<sub>2</sub>-binding properties to determine how blood-O<sub>2</sub> affinity would be affected by elimination of the major HbA isoHb (as would occur with the deletion of the  $\beta^A$  gene, leaving juvenile HbC as the sole-remaining isoHb). There was very little among-species variation in the measured O<sub>2</sub> affinities of either juvenile HbC or adult HbA (Table 1 and fig. S2), but the O<sub>2</sub> affinity of HbC exceeded that of HbA by a consistent margin (average, 10.6 torr) in all species (Table 1 and fig. S2). Moreover, O<sub>2</sub> affinity of

HbC alone was always substantially higher than that of the composite HbA + HbC mixture (with the two isoHbs present in their naturally occurring relative abundance) (Table 1 and fig. S2), reflecting the fact that the lower affinity HbA is always present as the major isoHb in adult red cells (average HbA/HbC ratio = ~80:20).

The higher Hb-O<sub>2</sub> affinity of Tibetan antelope relative to that of other bovid species is entirely attributable to a difference in isoHb composition: They only express the high-affinity HbC instead of jointly expressing HbA and HbC (with the lower-affinity HbA present as the major isoHb). To infer the direction of evolutionary change in isoHb-specific O<sub>2</sub> affinities and to reconstruct the phenotypic effect of deleting  $\beta^A$ -globin (thereby leaving HbC as the sole-expressed isoHb in adult red cells), we reconstructed the ancestral bovid  $\beta^A$  and  $\beta^C$  genes as well as their single-copy, preduplication progenitor ( $\beta^{AC}$ ) (Fig. 5 and fig. S3). Triangulated comparison of O<sub>2</sub> affinities of the three recombinantly expressed ancestral isoHbs, AncHb- $\beta^A$ , AncHb- $\beta^C$ , and AncHb- $\beta^{AC}$  (all of which had identical  $\alpha$  chains), revealed that the juvenile AncHb- $\beta^C$  evolved a slight increase in O<sub>2</sub> affinity relative to the estimated ancestral state (represented by AncHb- $\beta^{AC}$ ), whereas adult HbA evolved a slight reduction in O<sub>2</sub> affinity (Fig. 5). These data indicate that if HbA and HbC were present in a 80:20 ratio in the red cells of the Tibetan antelope ancestor (as in extant bovines), then the deletion of  $\beta^A$ -globin and the consequent elimination of HbA from the “HbA + HbC” composite mixture would result in a 13.5% increase in Hb-O<sub>2</sub> affinity in the presence of 100 mM Cl<sup>-</sup> ( $P_{50}$  decreased from 18.5 to 16.0 torr). Theoretical and experimental results indicate that an increase in Hb-O<sub>2</sub> affinity of this magnitude—if accompanied by a corresponding enhancement of tissue O<sub>2</sub> diffusion capacity—would likely translate into a physiologically important enhancement of aerobic exercise performance under hypoxia (6, 8–11).

**Table 1. Oxygenation properties of purified bovid Hbs.**  $P_{50}$  values are reported as means  $\pm$  SEM.  $\text{Cl}^-$  effect calculated as  $\log P_{50}[\text{+KCl}] - \log P_{50}[\text{stripped}]$ .

Hb solution	Species	$P_{50}$ , stripped (torr)	$P_{50}$ , +KCl (torr)	$\text{Cl}^-$ effect
Total Hb	European mouflon, <i>O. orientalis musimon</i>	12.08 $\pm$ 0.09	21.12 $\pm$ 0.20	0.24
	Snow sheep, <i>O. nivicola</i>	15.72 $\pm$ 0.12	29.91 $\pm$ 2.28	0.28
	Desert bighorn sheep, <i>O. canadensis nelsoni</i>	12.00 $\pm$ 0.42	22.98 $\pm$ 1.50	0.28
	Cretin wild goat, <i>C. aegagrus cretica</i>	14.43 $\pm$ 0.33	28.14 $\pm$ 0.10	0.29
	Nubian ibex, <i>C. nubiana</i>	11.20 $\pm$ 1.01	27.59 $\pm$ 0.57	0.39
	West caucasian tur, <i>C. caucasica</i>	10.90 $\pm$ 0.15	23.41 $\pm$ 0.21	0.33
	White-tailed gnu, <i>C. gnou</i>	14.27 $\pm$ 0.64	24.97 $\pm$ 0.78	0.24
	Blesbok, <i>D. pygargus phillipsi</i>	13.96 $\pm$ 1.09	27.59 $\pm$ 0.71	0.30
	Addax, <i>A. nasomaculatus</i>	13.07 $\pm$ 0.22	25.89 $\pm$ 0.62	0.30
	Indian gaur, <i>B. gaurus</i>	12.32 $\pm$ 0.14	27.50 $\pm$ 0.24	0.35
Pure HbA	Nubian ibex, <i>C. nubiana</i>	16.30 $\pm$ 0.19	32.79 $\pm$ 1.30	0.30
	West caucasian tur, <i>C. caucasica</i>	11.22 $\pm$ 0.42	23.79 $\pm$ 1.12	0.33
	Goat rHb, <i>C. hircus</i>	13.51 $\pm$ 0.21	26.33 $\pm$ 0.53	0.29
	Nubian ibex, <i>C. nubiana</i>	9.21 $\pm$ 0.22	19.41 $\pm$ 0.71	0.32
Pure HbC	West caucasian tur, <i>C. caucasica</i>	8.62 $\pm$ 0.12	18.03 $\pm$ 0.57	0.32
	Goat rHb, <i>C. hircus</i>	8.82 $\pm$ 0.33	18.29 $\pm$ 0.21	0.32
	Tibetan antelope rHb, <i>P. hodgsonii</i>	8.53 $\pm$ 1.10	18.59 $\pm$ 1.07	0.34

The derived blood phenotype of Tibetan antelope is consistent with the theoretical expectation that an increased Hb-O<sub>2</sub> affinity is adaptive under conditions of severe hypoxia (especially in highly athletic species) and is consistent with patterns observed in other high-altitude mammals and birds that maintain especially high rates of aerobic metabolism (25–33). In other case studies of high-altitude vertebrates, evolved increases in Hb-O<sub>2</sub> affinity have been traced to one or more amino acid substitutions in the  $\alpha$  and/or  $\beta$  chain subunits of the  $\alpha_2\beta_2$  Hb tetramer (6, 31–32). Here, we document a unique case in which an evolved change in Hb-O<sub>2</sub> affinity has been accomplished via a heterochronic shift in globin gene expression, such that a high-affinity, juvenile isoHb supplants the lower-affinity, adult isoHb. This juvenilization of blood properties represents a novel mode of biochemical adaptation and highlights the utility of heterochrony as an adaptive mechanism, whereby “...the existing channel of ordinary ontogeny already holds the raw material in a particularly effective state for evolutionary change” (2).

There has been debate in the literature regarding the relative importance of regulatory versus coding changes in genetic adaptation (34) and phenotypic evolution in general (35–36). In the case of Tibetan antelope, the evolved increase in Hb-O<sub>2</sub> affinity was caused by an unusual combination of regulatory and structural changes. Specifically, a marked regulatory switch in protein isoform expression (via truncation of the ancestral ontogeny of globin gene regulation)

was caused by a large-scale chromosomal deletion, highlighting the unexpected diversity of genetic mechanisms and substrates of phenotypic evolution.

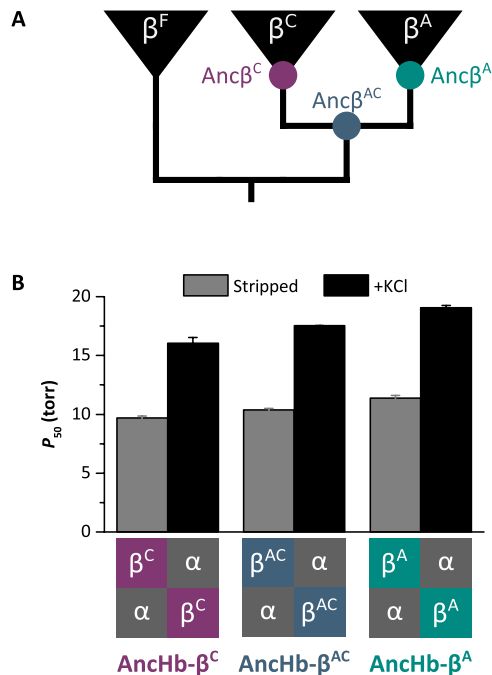
## MATERIALS AND METHODS

### Collection of blood samples

Frozen erythrocytes from 10 bovid species were provided by the San Diego Zoo Institute for Conservation Research (Uniform Biological Material Transfer Agreement BR2017063). This sample included six species in the subfamily Caprinae (*Capra aegagrus cretica*, *Capra caucasica caucasica*, *Ovis nivicola*, *Capra nubiana*, *Ovis orientalis musimon*, and *Ovis canadensis nelsoni*), two species in the subfamily Alcelaphinae (*Damaliscus pygargus phillipsi* and *Connochaetes gnou*), and one species of each from Hippotraginae (*Addax nasomaculatus*) and Bovinae (*Bos gaurus*).

### Sequencing of bovid globin genes

RNA was extracted from ~100  $\mu$ l of flash-frozen erythrocytes using an RNeasy Universal Plus Mini kit (QIAGEN). Complementary DNA (cDNA) was synthesized from freshly prepared RNA using SuperScript IV reverse transcriptase (Invitrogen). Gene specific primers were used to amplify the  $\alpha$ - and  $\beta$ -type globin transcripts. Polymerase chain reaction (PCR) reactions were conducted using



**Fig. 5. O<sub>2</sub> affinities of reconstructed ancestral bovid isoHbs.** (A) Reconstructed ancestral  $\beta$ -globin genes ( $\beta^C$ ,  $\beta^A$ , and  $\beta^{AC}$ ) of bovinds. (B) O<sub>2</sub> tensions at half saturation (mean  $P_{50} \pm$  SEM,  $n = 3$ ) for recombinant ancestral isoHbs in the absence (stripped) and presence of 0.1 M KCl at 37°C (pH 7.4) (0.1 mM Hb<sub>4</sub>). Schematic diagrams show the subunit composition of the three ancestral isoHbs (which have identical  $\alpha$  chains and structurally distinct  $\beta$  chains).

1 ml of cDNA template in 0.2-ml tubes containing 25  $\mu$ l of reaction mixture [0.5  $\mu$ l of each deoxynucleotide triphosphate (2.5 mM), 2.5  $\mu$ l of 10 $\times$  Reaction Buffer (Invitrogen), 0.75  $\mu$ l of 50 mM MgCl<sub>2</sub>, 1.25  $\mu$ l of each primer (10 pmol/ $\mu$ l), 1  $\mu$ l of Taq polymerase (Invitrogen), and 16.75  $\mu$ l of double-distilled H<sub>2</sub>O], using an Eppendorf Mastercycler Gradient thermocycler. Following a 5-min denaturation period at 94°C, the desired products were amplified using a cycling profile of 94°C for 30 s, 53° to 65°C for 30 s, 72°C for 45 s for 30 cycles, followed by a final extension period of 5 min at 72°C. Amplified products were run on a 1.5% agarose gel, and bands of the correct size were subsequently excised and purified using Zymoclean Gel DNA recovery columns (Zymo Research). Gel-purified PCR products were ligated into pCR4-TOPO vectors using a TOPO TA Cloning kit and were then transformed into One Shot TOP10 Chemically Competent *Escherichia coli* (Thermo Fisher Scientific). Three to six transformed colonies were cultured in 5 ml of LB medium, and plasmids were subsequently purified with a GeneJET Plasmid Miniprep kit (Thermo Fisher Scientific). Purified plasmids were sequenced by Eurofins Genomics.

### Sequence analyses

Genomic sequences containing the complete  $\alpha$ - and  $\beta$ -globin gene clusters for the domestic goat (*C. hircus*), sheep (*O. aries*), cow (*B. taurus*), and Tibetan antelope (*P. hodgsonii*) were obtained from GenBank (table S1). Sequence identity between bovid chromosomal regions containing the  $\beta$ -globin gene clusters was calculated using Blastn, and patterns of sequence matching were visualized using Easyfig 2.1 (37). Coding sequences of  $\alpha$ - and  $\beta$ -globin genes were

extracted from genomic and cDNA sequences available on GenBank (table S1) and were combined with the newly generated cDNA sequences mentioned above (fig. S3). Sequences were aligned using MUSCLE (38) and were then used to estimate phylogenetic trees. The best fitting codon substitution model and initial tree search were estimated using IQ-TREE with the options -st CODON, -m TESTNEW, -allni, and -bnni (39, 40). Initial trees were then subjected to 1000 ultrafast bootstrap replicates (41). Bootstrap consensus trees (fig. S1, A and B) were used to estimate ancestral globin sequences using IQ-TREE with the option -asr (figs. S1C and S3). As bovid  $\beta^C$ -globins are truncated by 9 base pairs (relative to  $\beta^A$ ), the ancestral reconstruction of indels in the  $\beta$ -globin gene tree was performed by FastML (42).

### Protein purification

Blood samples (~200  $\mu$ l) were added to a 5 $\times$  volume of ice-cold water and incubated on ice for 30 min to lyse the red blood cells. Samples were centrifuged at 20,000g for 10 min to remove cell debris. Buffer was added to the supernatants to a final concentration of 0.01 M HEPES/0.2 M NaCl (pH 7.4) and passed through a PD-10 desalting column (GE Healthcare) equilibrated with 25 ml of 0.01 M HEPES/0.5 mM EDTA (pH 7.2) to remove intracellular cofactors. Desalted lysates were loaded onto a HiTrap SP cation exchange column (GE Healthcare), and isoHbs were eluted using a linear pH gradient [0.01 M HEPES/0.5 mM EDTA (pH 7.2 to 7.7)]. For each species, a subsample of each isoHb was pooled to create a “Total Hb” solution. Each Hb solution was then desalted using a PD-10 column (GE Healthcare) equilibrated with 0.01 M HEPES/0.5 mM EDTA (pH 7.4), and eluates were concentrated using the Amicon Ultra-4 Centrifugal Filter Units (Millipore).

### Measuring O<sub>2</sub>-binding properties of purified Hbs

O<sub>2</sub> equilibrium curves for purified Hb solutions [0.1 mM Hb in 0.1 M HEPES/0.05 M EDTA buffer (pH 7.4)] were measured at 37°C using the Blood Oxygen Binding System (Loligo Systems). O<sub>2</sub> equilibrium curves were measured in the absence (stripped) and presence of chloride ions (0.1 M KCl). Each Hb solution was sequentially equilibrated with three to five different O<sub>2</sub> tensions ( $PO_2$ ) at saturation levels between 30 to 70%, while the absorbance was continually monitored at 430 nm (deoxy peak) and 421 nm (oxy/deoxy isosbestic point) (43–45). Hill plots ( $\log[\text{fractional saturation}/(1 - \text{fractional saturation})]$  versus  $\log PO_2$ ) constructed from these measurements were used to estimate the  $PO_2$  at half saturation ( $P_{50}$ ) and the cooperativity coefficient ( $n_{50}$ ) from the  $\chi$ -intercept and slope of these plots, respectively. O<sub>2</sub> equilibrium curves for each Hb solution were measured in triplicate, and  $P_{50}$  is reported as means  $\pm$  SEM.

### Construction of Hb expression vector

Globin sequences for domestic goat, Tibetan antelope, and the reconstructed ancestral globins were synthesized by GeneArt Gene Synthesis (Thermo Fisher Scientific) after optimizing the nucleotide sequences in accordance with *E. coli* codon preferences. The synthesized globin gene cassette was cloned into a custom pGM vector system along with the *methionine aminopeptidase* gene, as described previously (46).

### Expression and purification of recombinant Hbs

Recombinant Hb expression was carried out in the *E. coli* JM109 (DE3) strain as described previously (46–48). Bacterial cell lysates



were then loaded onto a HiTrap Q HP anion exchange column (GE Healthcare), then equilibrated with 20 mM tris/0.5 mM EDTA (pH 8.3), and eluted with a linear gradient of 0 to 0.25 M NaCl. Hb-containing fractions were then loaded on to a HiTrap SP HP cation exchange column (GE Healthcare) and eluted with a linear pH gradient (pH 6.8 to 8.4). Eluted Hb fractions were concentrated using the Amicon Ultra-4 Centrifugal Filter Units (Millipore), and oxygenation properties were measured as described above.

## SUPPLEMENTARY MATERIALS

Supplementary material for this article is available at <http://advances.sciencemag.org/cgi/content/full/6/25/eabb5447/DC1>

[View/request a protocol for this paper from Bio-protocol.](#)

## REFERENCES AND NOTES

- S. J. Gould, *Ontogeny and Phylogeny* (Harvard Univ. Press, 1977).
- S. J. Gould, *The Structure of Evolutionary Theory* (Harvard Univ. Press, 2002).
- R. E. Weber, Hemoglobin-based O<sub>2</sub> transfer in viviparous animals. *Israel J. Zool.* **40**, 541–550 (1994).
- T. Brittain, Molecular aspects of embryonic hemoglobin function. *Mol. Aspects Med.* **23**, 293–342 (2002).
- J. F. Storz, Gene duplication and evolutionary innovations in hemoglobin-oxygen transport. *Physiol.* **31**, 223–232 (2016).
- J. F. Storz, *Hemoglobin: Insights into Protein Structure, Function, and Evolution* (Oxford Univ. Press, 2019).
- D. S. Vinjamur, D. E. Bauer, S. H. Orkin, Recent progress in understanding and manipulating hemoglobin switching for the haemoglobinopathies. *Br. J. Haematol.* **180**, 630–643 (2018).
- J. F. Storz, G. R. Scott, Z. A. Cheviron, Phenotypic plasticity and genetic adaptation to high-altitude hypoxia in vertebrates. *J. Exp. Biol.* **213**, 4125–4136 (2010).
- J. F. Storz, Hemoglobin-oxygen affinity in high-altitude vertebrates: Is there evidence for an adaptive trend? *J. Exp. Biol.* **219**, 3190–3203 (2016).
- J. F. Storz, G. R. Scott, Life ascending: Mechanism and process in physiological adaptation to high-altitude hypoxia. *Annu. Rev. Ecol. Evol. Syst.* **50**, 503–526 (2019).
- P. B. Dominelli, C. C. Wiggins, S. E. Baker, J. R. A. Shepherd, S. K. Roberts, T. K. Roy, T. B. Curry, J. D. Hoyer, J. L. Oliveira, M. J. Joyner, Influence of high affinity hemoglobin on the response to normoxic and hypoxic exercise. *J. Physiol.* **598**, 1475–1490 (2020).
- M. H. Blunt, T. H. Huisman, J. P. Lewis, The production of haemoglobin C in adult sheep and goats. *Aust. J. Exp. Biol. Med. Sci.* **47**, 601–611 (1969).
- M. H. Blunt, M. Perry, R. Lane, The production of haemoglobin C by sheep at simulated high altitude. *R. Vet. Sci.* **11**, 191–193 (1970).
- A. Cymerman, J. T. Reeves, J. R. Sutton, P. B. Rock, B. M. Groves, M. K. Malconian, P. M. Young, P. D. Wagner, C. S. Houston, Operation Everest II: Maximal oxygen uptake at extreme altitude. *J. Appl. Physiol.* **66**, 2446–2453 (1989).
- M. A. Liu, S. Mahalingam, P. Patel, A. D. Connaty, C. M. Ivy, Z. A. Cheviron, J. F. Storz, G. B. McClelland, G. R. Scott, High-altitude ancestry and hypoxia acclimation have distinct effects on exercise capacity and muscle phenotype in deer mice. *Am. J. Physiol. Regul. Integr. Comp. Physiol.* **308**, R779–R791 (2015).
- J. F. Storz, Z. A. Cheviron, G. B. McClelland, G. R. Scott, Physiological performance capacities and environmental adaptation: Insights from high-elevation deer mice (*Peromyscus maniculatus*). *J. Mammal.* **100**, 910–922 (2019).
- H. B. Zhuang, W. D. Li, Z. H. Liu, Tibetan antelope (*Pantholops hodgsoni*). *Chin. J. Zool.* **38**, 74 (2003).
- R.-L. Ge, Q. Cai, Y.-Y. Shen, A. San, L. Ma, Y. Zhang, X. Yi, Y. Chen, L. Yang, Y. Huang, R. He, Y. Hui, M. Hao, Y. Li, B. Wang, X. Ou, J. Xu, Y. Zhang, K. Wu, C. Geng, W. Zhou, T. Zhou, D. M. Irwin, Y. Yang, L. Ying, H. Bao, J. Kim, D. M. Larkin, J. Ma, H. A. Lewin, J. Xing, R. N. Platt II, D. A. Ray, L. Auviel, B. Capitanu, X. Zhang, G. Zhang, R. W. Murphy, J. Wang, Y.-P. Zhang, J. Wang, Draft genome sequence of the Tibetan antelope. *Nat. Commun.* **4**, 1858 (2013).
- T. M. Townes, M. C. Fitzgerald, J. B. Lingrel, Triplication of a four-gene set during evolution of the goat beta-globin locus produced three genes now expressed differentially during development. *Proc. Natl. Acad. Sci. U.S.A.* **81**, 6589–6593 (1984).
- J. C. Schimenti, C. H. Duncan, Structure and organization of the bovine beta-globin genes. *Mol. Biol. Evol.* **2**, 514–525 (1985).
- M. J. Gaudry, J. F. Storz, G. T. Butts, K. L. Campbell, F. G. Hoffmann, Repeated evolution of chimeric fusion genes in the  $\beta$ -globin gene family of laurasiatherian mammals. *Gen. Biol. Evol.* **6**, 1219–1234 (2014).
- M. E. Clementi, R. Scatena, A. Mordente, S. G. Condò, M. Castagnola, B. Giardina, Oxygen transport by fetal bovine hemoglobin. *J. Mol. Biol.* **255**, 229–234 (1996).
- M. H. Blunt, T. H. J. Huisman, The haemoglobins of sheep, in *The Blood of Sheep: Composition and Function* (Springer, 1975), pp. 155–160.
- H. F. Bunn, Differences in the interaction of 2,3-diphosphoglycerate with certain mammalian hemoglobins. *Science* **172**, 1049–1050 (1971).
- J. F. Storz, A. M. Runck, H. Moriyama, R. E. Weber, A. Fago, Genetic differences in hemoglobin function between highland and lowland deer mice. *J. Exp. Biol.* **213**, 2565–2574 (2010).
- J. Projecto-García, C. Natarajan, H. Moriyama, R. E. Weber, A. Fago, Z. A. Cheviron, R. Dudley, J. A. McGuire, C. C. Witt, J. F. Storz, Repeated elevational transitions in hemoglobin function during the evolution of Andean hummingbirds. *Proc. Natl. Acad. Sci. U.S.A.* **110**, 20669–20674 (2013).
- S. C. Galen, C. Natarajan, H. Moriyama, R. E. Weber, A. Fago, P. M. Benham, A. N. Chavez, Z. A. Cheviron, J. F. Storz, C. C. Witt, Contribution of a mutational hot spot to hemoglobin adaptation in high-altitude Andean house wrens. *Proc. Natl. Acad. Sci. U.S.A.* **112**, 13958–13963 (2015).
- C. Natarajan, J. Projecto-García, H. Moriyama, R. E. Weber, V. Muñoz-Fuentes, A. J. Green, C. Kopuchian, P. L. Tubaro, L. Alza, M. Bulgarella, M. M. Smith, R. E. Wilson, A. Fago, K. G. McCracken, J. F. Storz, Convergent evolution of hemoglobin function in high-altitude Andean waterfowl involves limited parallelism at the molecular sequence level. *PLoS Genet.* **11**, e1005681 (2015).
- C. Natarajan, F. G. Hoffmann, H. C. Lanier, C. J. Wolf, Z. A. Cheviron, M. L. Spangler, R. E. Weber, A. Fago, J. F. Storz, Intraspecific polymorphism, interspecific divergence, and the origins of function-altering mutations in deer mouse hemoglobin. *Mol. Biol. Evol.* **32**, 978–997 (2015).
- D. M. Tufts, C. Natarajan, I. G. Revsbech, J. Projecto-García, F. G. Hoffmann, R. E. Weber, A. Fago, H. Moriyama, J. F. Storz, Epistasis constrains mutational pathways of hemoglobin adaptation in high-altitude pikas. *Mol. Biol. Evol.* **32**, 287–298 (2015).
- C. Natarajan, F. G. Hoffmann, R. E. Weber, A. Fago, C. C. Witt, J. F. Storz, Predictable convergence in hemoglobin function has unpredictable molecular underpinnings. *Science* **354**, 336–339 (2016).
- X. Zhu, Y. Guan, A. V. Signore, C. Natarajan, S. G. DuBay, Y. Cheng, N. Han, G. Song, Y. Qu, H. Moriyama, F. G. Hoffmann, A. Fago, F. Lei, J. F. Storz, Divergent and parallel routes of biochemical adaptation in high-altitude passerine birds from the Qinghai-Tibet Plateau. *Proc. Natl. Acad. Sci. U.S.A.* **115**, 1865–1870 (2018).
- A. V. Signore, Y.-Z. Yang, Q.-Y. Yang, G. Qin, H. Moriyama, R.-L. Ge, J. F. Storz, Adaptive changes in hemoglobin function in high-altitude Tibetan canids were derived via gene conversion and introgression. *Mol. Biol. Evol.* **36**, 2227–2237 (2019).
- H. E. Hoekstra, J. A. Coyne, The locus of evolution: Evo devo and the genetics of adaptation. *Evolution* **61**, 995–1016 (2007).
- S. B. Carroll, Evo-devo and an expanding evolutionary synthesis: A genetic theory of morphological evolution. *Cell* **134**, 25–36 (2008).
- D. L. Stern, V. Orgogozo, Is genetic evolution predictable? *Science* **323**, 746–751 (2009).
- M. J. Sullivan, N. K. Petty, S. A. Beatson, Easyfig: A genome comparison visualizer. *Bioinformatics* **27**, 1009–1010 (2011).
- R. C. Edgar, MUSCLE: Multiple sequence alignment with high accuracy and high throughput. *Nuc. Acid. Res.* **32**, 1792–1797 (2004).
- L.-T. Nguyen, H. A. Schmidt, A. von Haeseler, B. Q. Minh, IQ-TREE: A fast and effective stochastic algorithm for estimating maximum-likelihood phylogenies. *Mol. Biol. Evol.* **32**, 268–274 (2015).
- S. Kalyaanamoorthy, B. Q. Minh, T. K. F. Wong, A. von Haeseler, L. S. Jermiin, ModelFinder: Fast model selection for accurate phylogenetic estimates. *Nat. Met.* **14**, 587–589 (2017).
- D. T. Hoang, O. Chernomor, A. von Haeseler, B. Q. Minh, L. S. Vinh, UFBoot2: Improving the ultrafast bootstrap approximation. *Mol. Biol. Evol.* **35**, 518–522 (2018).
- H. Ashkenazy, O. Penn, A. Doron-Faigenboim, O. Cohen, G. Cannarozzi, O. Zomer, T. Pupko, FastML: A web server for probabilistic reconstruction of ancestral sequences. *Nuc. Acid. Res.* **40**, W580–W584 (2012).
- M. T. Grispro, C. Natarajan, J. Projecto-García, H. Moriyama, R. E. Weber, J. F. Storz, Gene duplication and the evolution of hemoglobin isoform differentiation in birds. *J. Biol. Chem.* **287**, 37647–37658 (2012).
- J. F. Storz, C. Natarajan, H. Moriyama, F. G. Hoffmann, T. Wang, A. Fago, H. Malte, J. Overgaard, R. E. Weber, Oxygenation properties and isoform diversity of snake hemoglobins. *Am. J. Physiol. Regul. Integr. Comp. Physiol.* **309**, R1178–R1191 (2015).
- A. Fago, C. Natarajan, M. Pettinati, F. G. Hoffmann, T. Wang, R. E. Weber, S. I. Drusin, F. Issoglio, M. A. Martí, D. Estrin, J. F. Storz, Structure and function of crocodylian hemoglobins and allosteric regulation by chloride, ATP, and CO<sub>2</sub>. *Am. J. Physiol. Regul. Integr. Comp. Physiol.* **318**, R657–R667 (2020).
- C. Natarajan, X. Jiang, A. Fago, R. E. Weber, H. Moriyama, J. F. Storz, Expression and purification of recombinant hemoglobin in *Escherichia coli*. *PLOS ONE*. **6**, e20176 (2011).

47. C. Natarajan, N. Inoguchi, R. E. Weber, A. Fago, H. Moriyama, J. F. Storz, Epistasis among adaptive mutations in deer mouse hemoglobin. *Science* **340**, 1324–1327 (2013).
48. Z. A. Cheviron, C. Natarajan, J. Projecto-Garcia, D. K. Eddy, J. Jones, M. D. Carling, C. C. Witt, H. Moriyama, R. E. Weber, A. Fago, J. F. Storz, Integrating evolutionary and functional tests of adaptive hypotheses: A case study of altitudinal differentiation in hemoglobin function in an Andean sparrow, *Zonotrichia capensis*. *Mol. Biol. Evol.* **31**, 2948–2962 (2014).

**Acknowledgments:** We thank C. Natarajan for assistance in the laboratory and K. Campbell for comments on this manuscript. **Funding:** This study was funded by grants to J.F.S. from the NIH (HL087216) and the NSF (MCB-1517636 and OIA-1736249). **Author contributions:** A.V.S. and J.F.S. designed the study, A.V.S. acquired the data, and A.V.S. and J.F.S. analyzed the data and wrote the manuscript. **Competing interests:** The authors declare that they have no competing interests. **Data and materials availability:** All data needed to evaluate the

conclusions in the paper are present in the paper and/or the Supplementary Materials. Sequence data collected as part of this study are deposited to GenBank under accession numbers MT341275–MT341298. Additional data related to this paper may be requested from the authors. Biological materials can be provided by J.F.S. pending scientific review and a completed material transfer agreement. Requests for biological materials should be submitted to the corresponding author.

Submitted 2 March 2020

Accepted 11 May 2020

Published 17 June 2020

10.1126/sciadv.abb5447

**Citation:** A. V. Signore, J. F. Storz, Biochemical pedomorphosis and genetic assimilation in the hypoxia adaptation of Tibetan antelope. *Sci. Adv.* **6**, eabb5447 (2020).

## Biochemical pedomorphosis and genetic assimilation in the hypoxia adaptation of Tibetan antelope

Anthony V. Signore and Jay F. Storz

*Sci Adv* 6 (25), eabb5447.  
DOI: 10.1126/sciadv.abb5447

ARTICLE TOOLS	<a href="http://advances.sciencemag.org/content/6/25/eabb5447">http://advances.sciencemag.org/content/6/25/eabb5447</a>
SUPPLEMENTARY MATERIALS	<a href="http://advances.sciencemag.org/content/suppl/2020/06/15/6.25.eabb5447.DC1">http://advances.sciencemag.org/content/suppl/2020/06/15/6.25.eabb5447.DC1</a>
REFERENCES	This article cites 44 articles, 12 of which you can access for free <a href="http://advances.sciencemag.org/content/6/25/eabb5447#BIBL">http://advances.sciencemag.org/content/6/25/eabb5447#BIBL</a>
PERMISSIONS	<a href="http://www.sciencemag.org/help/reprints-and-permissions">http://www.sciencemag.org/help/reprints-and-permissions</a>

Use of this article is subject to the [Terms of Service](#)

---

*Science Advances* (ISSN 2375-2548) is published by the American Association for the Advancement of Science, 1200 New York Avenue NW, Washington, DC 20005. The title *Science Advances* is a registered trademark of AAAS.

Copyright © 2020 The Authors, some rights reserved; exclusive licensee American Association for the Advancement of Science. No claim to original U.S. Government Works. Distributed under a Creative Commons Attribution NonCommercial License 4.0 (CC BY-NC).